



shown in Gloss White with Walnut blades

shown in Gloss White with Gloss White blades

WET LOCATION

Eliza

Geometry in Motion

Designed in 2013



shown in Brushed Nickel with Gray Ash blades

shown in Brushed Nickel with Brushed Nickel blades

Blade Options



Designed by Chicago architect Stephen Katz in 2013, the wet location Eliza blends a beautiful technically derived form with superior function and movement. The unique blade shape is designed to maximize air movement at the outer edge of the blade. The result is more efficient air velocity rings, less blade drag and greater motor optimization. Equally important is Eliza's stationary visual statement which combines modern utility with minimalist geometry.

- 56" diameter.
- Energy efficient, ultra-quiet, six-speed and reversible DC motor with new reliable technology.
- Wet location finishes: brushed nickel and gloss white.
- Blades available in Gloss White, Brushed Nickel, Walnut or Gray Ash.
- Constructed of cast aluminum, polycarbonate and heavy stamped steel.
- Limited Lifetime Warranty
- Standard equipment:
 - One downrod of 10". 5", 20", 30", 48" or 72" downrods also available.
 - Vaulted ceiling mount canopy for up to 30 degrees.
 - Reverse on six-speed, hand-held and wall-mountable remote control.

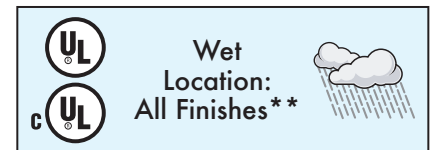

Eliza

weight: 17 lbs
voltage: 110/220

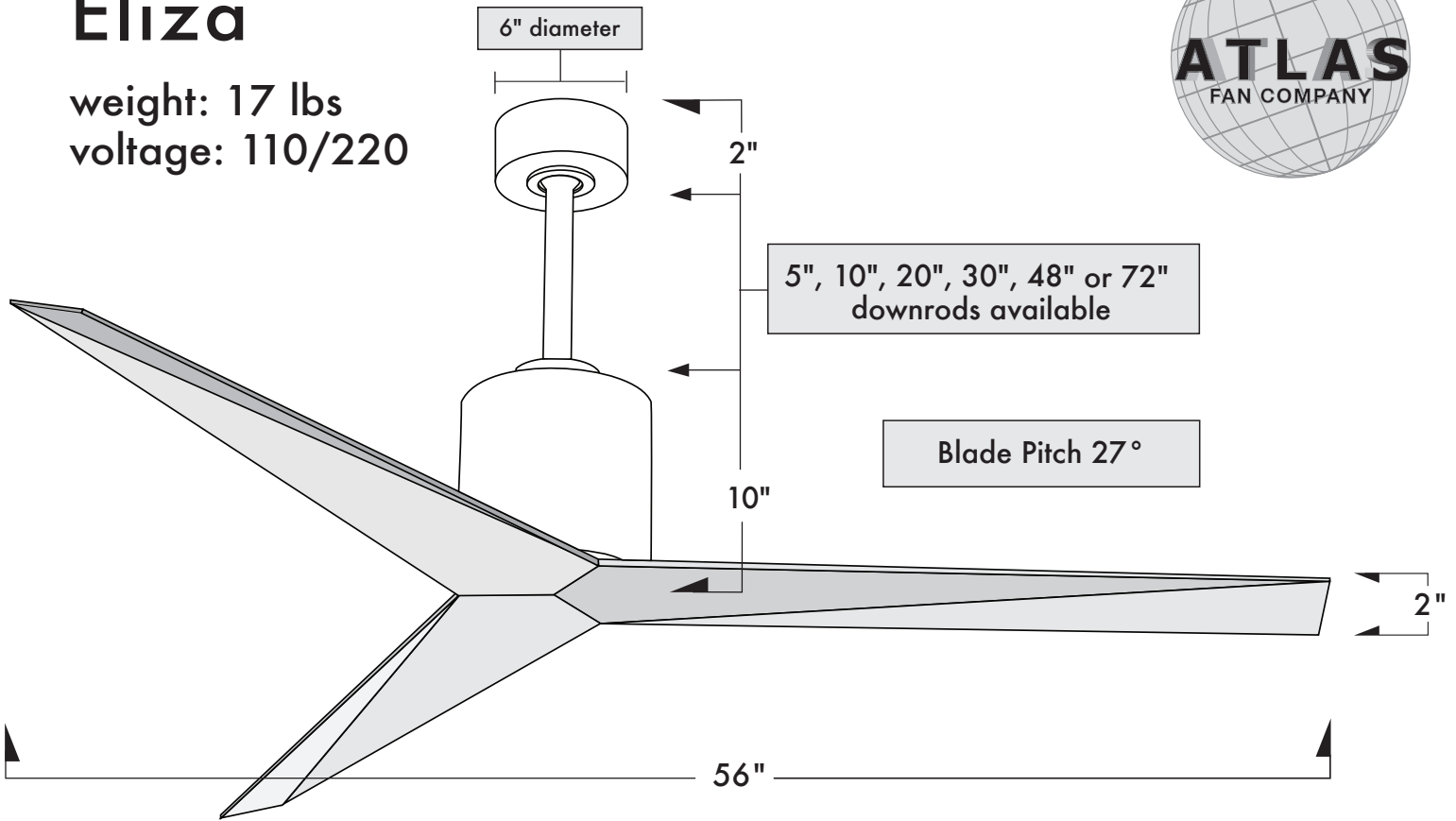

SKU Naming Convention	
EK-XX-XX (Finish-Blade Finish)	
Finish	Blade Finish
Brushed Nickel - BN	Brushed Nickel - BN
Gloss White - WH	Gloss White - WH
	Walnut - WN
	Gray Ash - GA

CFM
5396



- 1) The Eliza is compatible with flat or vaulted ceilings and can be mounted with any one of the following downrod lengths: 5", 10", 20", 30", 48" and 72".
- 2) The Eliza is also compatible with a proprietary decora-style accessory wall control: DC-WC.

**Wet location: All standard finishes. Not recommended for salt water/ocean front applications.